

NOTICE WARNING CONCERNING COPYRIGHT RESTRICTIONS:

The copyright law of the United States (title 17, U.S. Code) governs the making of photocopies or other reproductions of copyrighted material. Any copying of this document without permission of its author may be prohibited by law.

Operating Procedure Synthesis: A Tutorial

by

R. H. Fusillo and G. J. Powers

EDRC-06-31-87

Operating Procedure Synthesis: A Tutorial

Robert H. Fusillo

and

Gary J. Powers

Department of Chemical Engineering

with

William J. Wrbican

Department of English

Carnegie-Mellon University

ABSTRACT

A tutorial for teaching Chemical Engineering students newly developed methods of operating procedure synthesis is presented. Based on previous research in developing a formal approach to operating procedure synthesis, the methods shown combine planning strategies from Artificial Intelligence with causal models. The tutorial introduces concepts such as system decomposition, modelling, constraint analysis, and planning. An example is then presented, showing applications of these concepts to a chemical processing system.

developed algorithms for path finding and for discovering orderings of valve operations. An example was presented which made use of constraints such as all flow being prohibited in a certain location.

Kinoshita, et al. [9] defined the problem of operating procedure synthesis as that of generating a sequence of state transitions for carrying the process between initial and final goal states. The plant was divided into subsystems consisting of small groups of connected units. They outlined a proposed method involved generating the required state transition for each subsystem, without considering the connectivity between subsystems. It was then proposed to time operations to ensure consistency between subunits. Kinoshita and co-workers recognized the role of constraints in limiting the search space for procedure synthesis.

Ivanov and co-workers [7,8] developed algorithms for optimal startup sequences for chemical processes for subsequent realization on process control computers. They represented the startup process in the form of a transition graph, in which nodes represented possible combinations of system state parameters, and arcs represented possible ways of carrying the system between states under action of corresponding control variables. Each arc carried with it a weighting factor, based on the chosen optimality criterion. Algorithms were developed for finding optimal paths through the nodes. Startup sequences thus found could be used as the basis for writing startup programs.

These workers have illustrated the difficulties involved in developing a formal approach to the synthesis of operating procedures. The search space is very large and there is considerable difficulty in representing the wide range of constraints and interactions involved. The method described below combines strategies for planning drawn from Artificial Intelligence research with causal models based on process mass, energy, and momentum balances. The method also owes a great deal to the engineers who shared numerous operating procedures and strategies with us.

Fusillo and Powers presented a method of systematic synthesis of operating procedures on a global scale [4]. Using a state-space search for plans, combined with symbolic modelling, we were able to devise a method of procedure planning based on

means-ends analysis. A chemical processing system is viewed as a sequence of "goal states." The synthesis of operating procedures is then a set of actions which brings the system from some initial state to the desired goal state. Hence, procedure synthesis can be represented as a state space, with operators used to move between states. A state is represented by a vector of physical quantities, such as temperature, pressure, concentrations, flow rates, etc. A state space operator represents a manipulation of the process equipment. A similar state space representation was used by Siirola, Powers, and Rudd [12,13] for their work in process synthesis. An experimental program called POPS (Prototype Operating Procedure Synthesis program) was introduced, in which some of our methods were implemented.

Later work [5] illustrated extensions to include the purging of chemical processing systems. The combinatorial problem was greater due to the larger number of decisions required for each chemical species and possible contaminant. Direct application of means-ends analysis is often not sufficient to formulate purge goals. Constraint analysis is used to determine if species present at the initial state are allowable at the goal state. Undesirable components are added to a "forbidden components" list and a goal is formulated to purge each component on the list.

The goal in this tutorial is to provide an introduction to operating procedure synthesis for students in Chemical Engineering, giving an introduction to a systematic approach to writing operating procedures. Traditionally, this is not a part of the chemical engineering curriculum. However, the value of teaching operating procedure synthesis as part of a process design or control course is being recognized. Newly-hired engineers, despite their inexperience, are often assigned to write operating manuals. Process design engineers should keep operability in mind as they design a facility; it is often expected that the design engineers will submit a preliminary operating plan as part of a completed design.

This tutorial will present a description of some of the methods that have been developed for operating procedure synthesis. Issues which are addressed include system decomposition, modelling, constraint handling, and techniques for planning and search. A step-by-step description of planning the startup of a chemical plant will also

be described in Section 3. You will be asked to solve a start up procedure problem. At the end of this tutorial the reader should be able to:

1. Identify a procedure synthesis problem by stating the initial and goal states.
2. Determine constraints on the system.
3. Identify appropriate unit manipulations through means-ends analysis.
4. Search and evaluate procedure paths.
5. Describe and criticize alternate procedures.
6. Produce procedures for use by human operators.

2. METHOD

2.1 PROBLEM REPRESENTATION

The operation of a chemical processing system can be viewed as a sequence of 'goal states,' such as plant commissioning, pre-startup, normal running, hot shutdown, and cold shutdown. The synthesis of operating procedures can then be viewed as finding a set of actions which would bring the system from some initial state to a goal state, subject to constraints dictated by consideration of process chemistry, process equipment, safety, and environmental consequences.

Procedure synthesis can be represented as a state space, as illustrated in Figure 1, with operators used to move between states. In the domain of operating procedure synthesis, a state is represented by a vector of physical quantities, such as temperatures, pressures, levels, compositions, phases, and valve positions. A state-space operator represents a manipulation of the process equipment, such as opening a valve or activating a pump, compressor, controller, etc.

The sequence of operations for establishing desired process conditions is represented as a path between the initial and goal states, using available operators to go from state to state. There are, in many cases, multiple ways to travel between the initial and goal states. This is demonstrated in Figure 1 by two paths spanning from the initial state to the goal state. An evaluation of the alternative paths could be based on feasibility of the path, time, cost, or some combination of criteria. It is also demonstrated in Figure 1 that there can be planning paths which fail to reach the goal state. In the present domain, such paths represent sequences of tasks which are ineffective in reaching the operating goals. Such paths can lead to hazards such as toxic releases or explosions. One of the primary goals of this procedure synthesis methodology is the avoidance of these dangerous paths.

2.2 SYSTEM DECOMPOSITION

The operating procedure synthesis problem is greatly facilitated by decomposing, for purposes of planning, the process plant into smaller subsystems. Proper

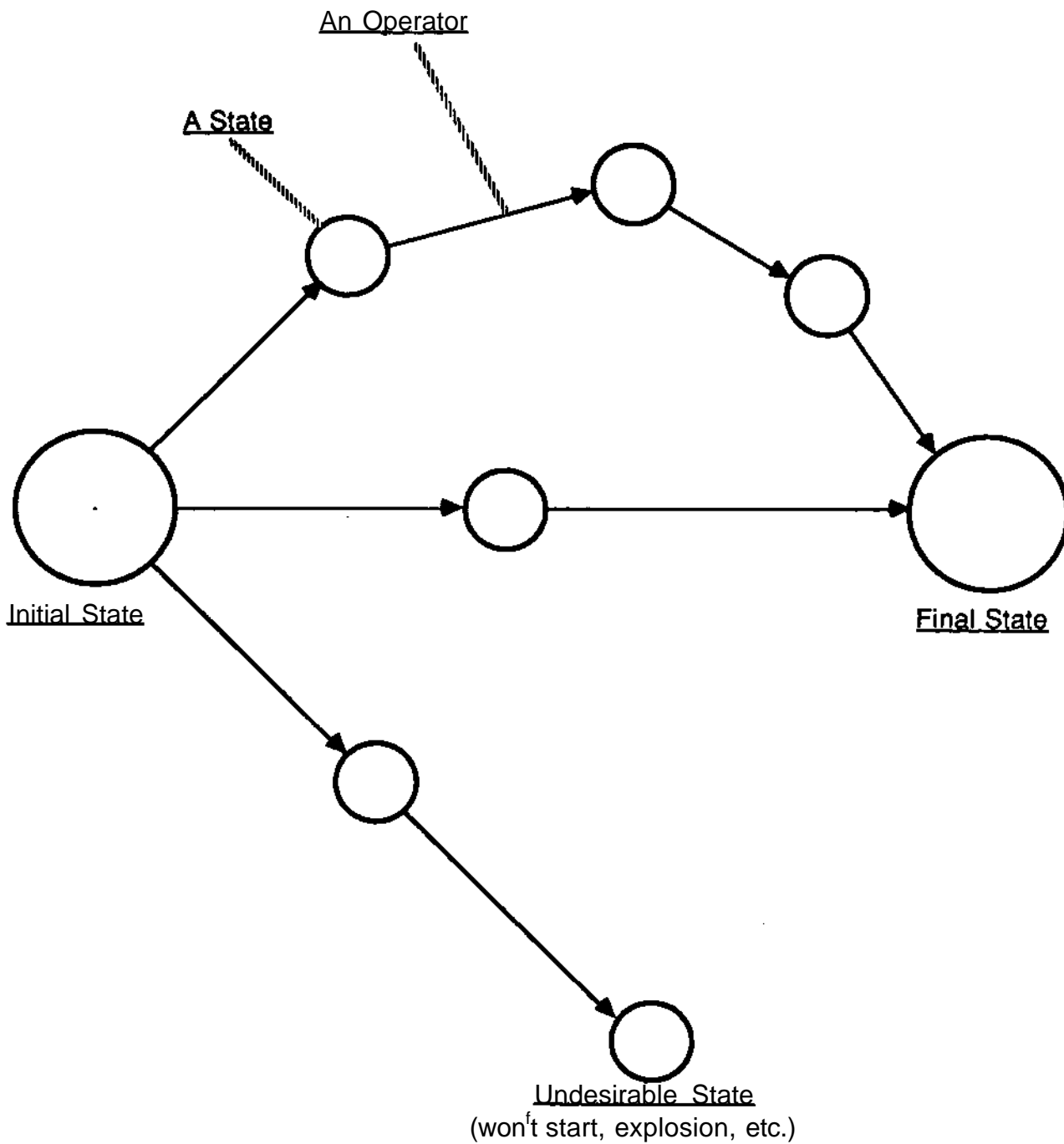

Figure 1. A Planning State Space

decomposition allows the interactions between subsystems to be reduced during specific time periods.

Decomposition is performed according to the following criteria:

1. Subsystems consist of one or more major process units along with the required connections and instrumentation. The units contained in a subsystem share a common function. A subsystem might, for instance, perform a chemical reaction, separation, feed preparation, etc.
2. A subsystem should be able to be physically isolated from neighboring subsystems.
3. A subsystem should, whenever possible, be chosen to have *stationary states*.

A stationary state is a condition at which the operating goals are partly met and the system does not change overtime. Systems with stationary states can be characterized by certain recognizable criteria. The presence of *simultaneous inverse* operations indicates the possibility of a stationary state in a process. This occurs where a transformation is performed on one part of a process, and the inverse transformation is performed in a connected part of the process. A simple example would be a closed flow loop with a pump in line: momentum is imparted to the fluid by the pump, momentum is lost to friction in the piping. Systems with large capacitance for a physical quantity may also have stationary states. Stationary states have the following common characteristics:

1. The subsystem is at steady state, or is changing very slowly.
2. The values of the state variables lie between shutdown and final run state. Often, the subsystem has been inventoried with most of the material required for its final run state, and, if the subsystem has large thermal mass, the temperature goals are partly met.
3. Connections between a subsystem and its neighbors are closed, so the subsystems do not interact.

A distillation column is an example of a class of systems with simultaneous inverse

operations. Evaporation occurs at the bottom of the column, and condensation occurs at the top. As a result, a column may be operated at total reflux with a pure component or some mixture until the column can be integrated operationally with other subsystems. Operation at total reflux is one potential stationary state for a distillation column.

Another class of processing systems with stationary states are those with large capacitance for a physical quantity, such as thermal energy, pressure, or material. A stationary state for a liquid-phase continuous stirred-tank reactor might be the condition where the reaction vessel is filled with one reactant and/or solvent and the contents heated until all other reactants are ready to be fed. A gas-phase recycle reactor loop can be heated, raised to the desired pressure, and operated at total recycle until all the other necessary reactants are available. Thus, the stationary state for such a system takes advantage of both simultaneous inverse operations (with respect to momentum) and capacitance (with respect to material and thermal energy).

Stationary states are useful for real-time operations and for efficient procedure planning. Stationary states provide convenient and verifiable stopping-off points during operations and they allow recovery states for emergencies, repairs, and maintenance. Stationary states also serve as focal points for overall operating strategies. One startup strategy for a continuous chemical plant is to establish the stationary states for the subsystems while physical pathways between them are closed, then to operationally integrate the subsystems and bring the entire system to a steady running state. The procedures to establish the individual stationary states can be retrieved from a data base or synthesized if there are no pre-existing procedures. At that stage of planning, subsystem interactions will be weak and usually negligible. Following this, procedures can be synthesized to integrate the subsystems and bring the entire system to its normal running state. In this step of planning, dynamics and interactions between subsystems must be taken into account.

Consider the cyclohexane flowsheet in Figure 2. Perception of this flowsheet reveals two subsystems, both of which have stationary states of which advantage can be taken during startups and warm shutdowns. In decomposing the system, the division is made at valve V-1, resulting in reaction and separation subsystems. Upstream from

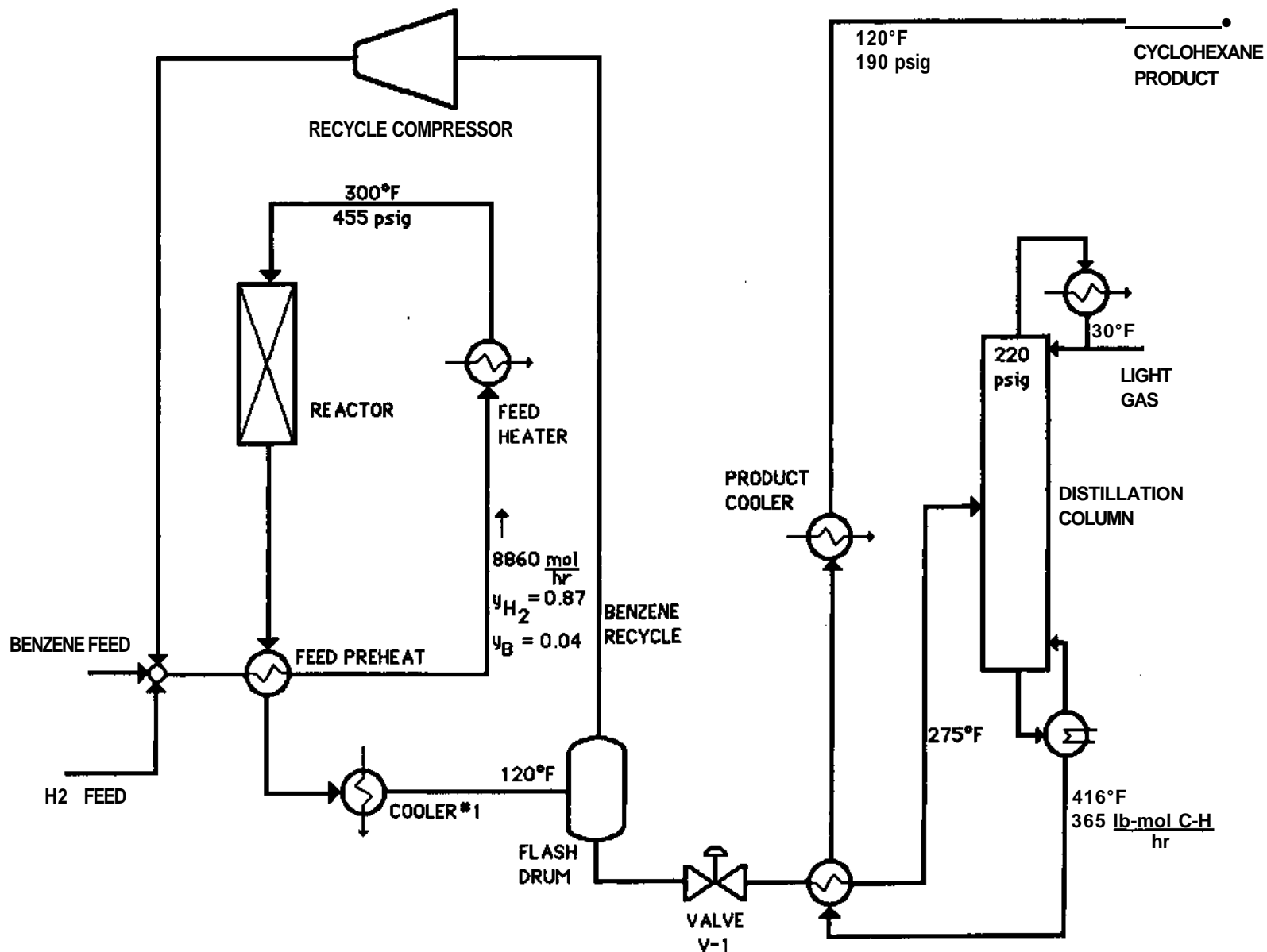

Figure 2. Cyclohexane plant flowsheet (adapted from [15]).

valve V-1 is a heat-integrated gas-phase recycle reactor loop, and downstream is a distillation system. The first steps in startup of this process could be to independently establish the stationary states of the reaction and distillation subsystems. Once the recycle reactor loop is cycling hot benzene vapor and the distillation column has been charged with cyclohexane and is operating at total reflux, the system will be stable until hydrogen feed is introduced and steps are taken to integrate the reaction and distillation subsystems.

Stationary states are used in planning as target states. This resembles "island-driven" planning in artificial intelligence [2], which reduces the search space by identifying states to be passed through between the initial and final states.

Question for thought:

1. If the reactor in Figure 2 were changed to a liquid/vapor phase continuous stirred tank reactor with a large liquid capacitance, what additional stationary states might be possible? What conditions should be added to the initial state vector (i.e. initial liquid level in reactor = 0, mixing on or off, etc.)?

2.3 MODELLING

The synthesis of operating procedures requires a wide range of modelling methods. Much of the modelling for planning operating procedures can be based on qualitative techniques similar to those used in artificial intelligence programs. More detailed modelling techniques are available, such as causal models similar to those used in failure analysis [10] and control system synthesis [6]. The feasibility of certain procedural steps will require more detailed quantitative modelling of system dynamics.

In our research in operating procedure synthesis, we have developed a method of functional modelling, which is similar to the add- and delete-lists used in the STRIPS planning program of Fikes and Nilsson [3]. In functional modelling, units in a flowsheet are modelled as sources and sinks of energy, momentum, and material. The choice of operations to satisfy goals to change physical quantities is based on manipulation of the

appropriate sources and sinks. Each unit in a subsystem is modelled by lists of effects which operations of the unit would have on a subsystem. Variables in functional modelling are defined "globally" within a subsystem. For each subsystem, global levels of temperature, pressure, compositions, and flowrates are defined. To simulate the effect of manipulation of a unit, the effects of the operations are expressed directly as changes of subsystem variables. These subsystem variables take on multiple, discrete values. A variable value is a member of the set {zero, low-low, low, med-low, medium, med-high, high, high-high}. The correspondence between the discrete global variables and the continuous process variables is determined by the expected ranges of the process variables.

Figure 3 shows a compressor and a heat exchanger with controllers on a closed flow loop. The operation of increasing the set point on the temperature controller is modelled by a list of changes to the state variables:

```

INCREASE-HEATER {value-t}
  TEMP <- value-t
  PRESSURES- fcn-1 {value-t}

```

where *value-t* is an argument representing the new set point and *fcn-1* is a function which qualitatively computes the new value of the pressure. Likewise, starting the compressor is modelled as follows:

```

START-COMPRESSOR (value-f)
  FLOW <- value-f
  TEMP <- fcn-2 {value-f}

```

where *value-f* represents the new flow set point and *fcn-2* is a qualitative function to compute the new value of the temperature.

To aid planning, each unit type is marked as a source or sink of one or more variable. In the example above, the heat exchanger would be identified as a source of temperature (thermal energy), and the compressor would be marked as a source of flow (momentum). In the functional models of these units, both these primary effects and side effects are included.

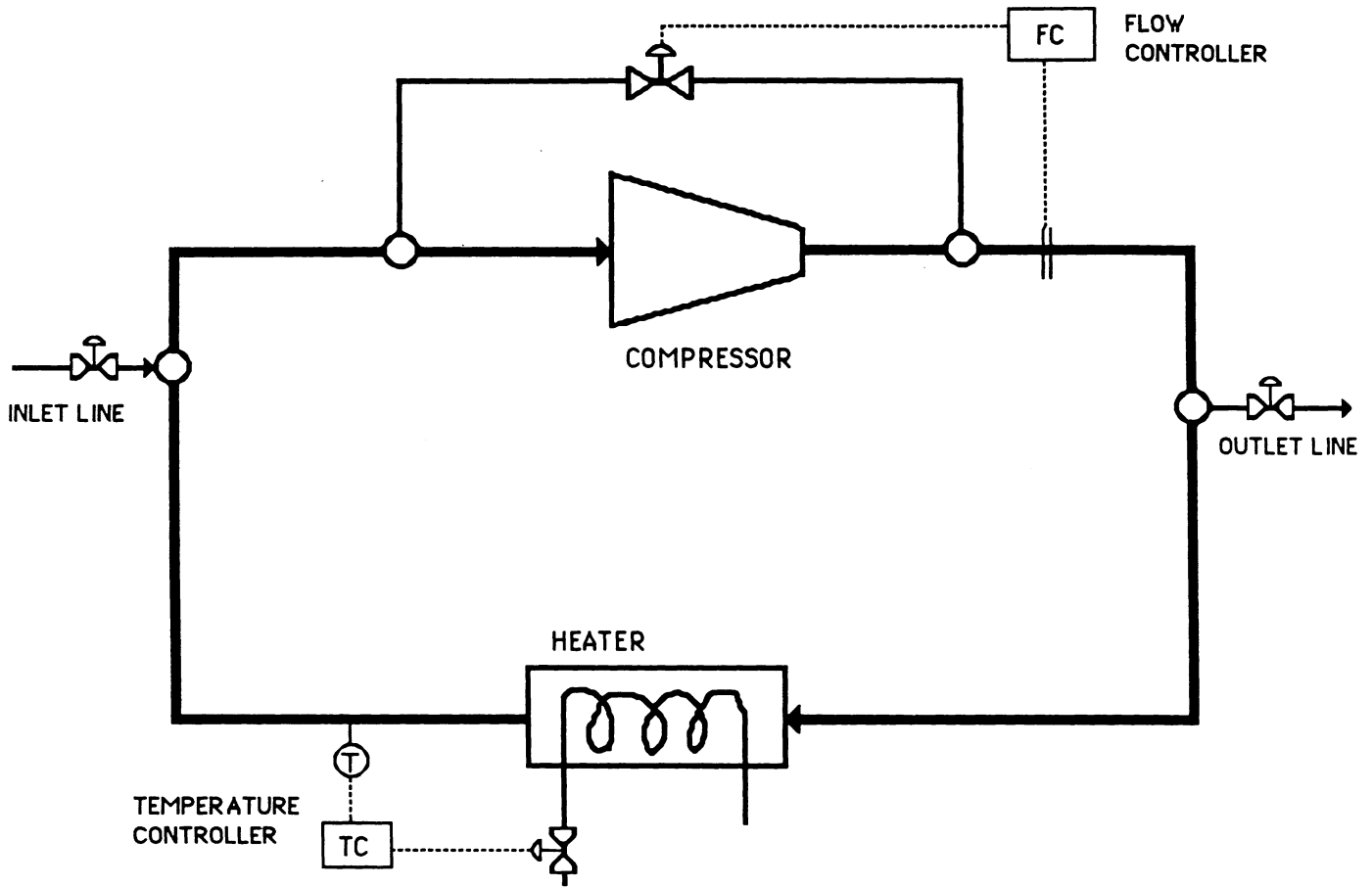

Figure 3. Closed flow loop with heater and compressor.

Questions for thought:

1. For the flash drum in Figure 2, develop a functional model that represents the relationships between the input and output variables:
 - a. Amount of liquid in the drum
 - b. The concentration of H₂ in the liquid leaving the drum
 - c. The concentration of cyclohexane in the liquid leaving the drum and the temperature, pressure, and composition of the flash drum inlet stream.

2. For the packed bed reactor in Figure 2, develop a functional model that represents the relationship of conversion of benzene per pass with respect to temperature, pressure, flowrate and H₂ concentration entering the reactor.

2.4 CONSTRAINTS

The operation of chemical plants is a highly constrained domain. Constraints are generated *a priori* by considering these factors:

- Preconditions for unit operations -- To avoid damage to the unit, or to ensure correct operation, some condition must often exist before a task can be performed.
- Requirements for a reaction - All reactants plus any catalyst must be present in proper concentrations, in the correct phases, at the correct temperatures, etc.
- Production requirements - this dictates allowable impurities as well as plant throughput and product concentrations.
- Hazards — e.g., explosions or dangers to the environment. These considerations cause species to be prohibited in certain locations or prohibit the contacting of certain species.
- Materials of construction - This may prohibit certain species or mixtures from entering the system or dictate the allowable ranges of temperatures and pressures.

In planning systems, constraints are used to limit the search space and reduce the planning effort [16]. For our methodology of operating procedure synthesis, constraints are used to help select process equipment and materials where choices exist, and to help order process tasks.

We make the distinction between *local* and *global* constraints, because of the location of the constraints and the way they are used in the planning process. In both cases, constraints are expressed symbolically. Local constraints are due to preconditions for process tasks, for instance:

DO NOT OPERATE HEATER HTR-25 WITH NO FLOW IN ITS TUBES

(to avoid damage to tubes).

An example of a global constraint due to system chemistry is:

DO NOT MIX O₂ AND CH₄ (to avoid an explosion hazard).

Questions for thought:

1. Develop additional constraints for the flowsheet in Figure 2 based on the following facts. Are they local or global? Why?
 - a. Sulfur impurities in benzene poison the catalyst in the reactor.
 - b. Hydrogen sulfide (H₂S) byproducts from the reaction, if combined with water, can create sulfuric acid.
 - c. Inert gases accumulate in the condensers.
 - d. Liquid droplets in the inlet to compressors cause turbine blade damage.

2.5 PLANNING

The core of a systematic synthesis method for operating procedures is the method by which decisions are made. The decision-making method presented here involves identifying the conditions which must be changed by the operating procedures, translating the identified changes into tasks to be performed by the operating personnel, and ensuring that the proposed sequence of tasks will achieve the overall goals of plant operations. We have already introduced the use of stationary states as targets in

island-driven planning. If intermediate stationary states can be located, they can reduce the search effort involved in planning. This section will discuss planning of procedures for carrying the process between target states.

Planning for procedure synthesis may be posed as a means-ends analysis problem where the initial and goal states are characterized by vectors describing the process at both ends of planning. For instance, when planning the startup of a continuous process, the initial state vector contains the temperatures, pressures, flowrates, compositions, flowrates, etc., describing the shutdown process, and the final state vector contains the state variable values at the steady running state. In means-ends analysis, an initial state and a final state are compared, and differences between the two states are discovered. Figures 5 and 6 in Section 3 show an example of an application of means-ends analysis. Each encircled delta represents a difference in a state variable. A goal is formulated to reduce each difference.

The next step in performing means-ends analysis is to search for an operator to satisfy each goal. In the domain of operating procedure synthesis, an operator is some manipulation done to the chemical process. In order to find these operators, we make use of sources and sinks of physical quantities. For example, given the goal: "INCREASE TEMPERATURE," we seek to increase the operating level of a source of thermal energy or decrease the operating level of a sink of thermal energy.

The search for operators produces a set, not necessarily minimal or complete, of unit manipulations. Planning of these manipulations will proceed hierarchically: the first manipulations to be proposed will be "macroscopic," i.e., an operation like "START COMPRESSOR" may be proposed as a single operation, whereas the task of starting a compressor may require the starting of seal flush and lubricating oil units, multiple valving operations, and starting the compressor motor. Operating tasks of other major process units such as heaters and distillation columns, can be similarly decomposed as subtasks.

Depth-first, forward search is used to discover sequences of operators which meet the operating goals and do not violate constraints. The following is a detailed description of the sequencing algorithm:

- (1) Let the current state be the initial state.
- (2) If there are no operators which are not yet placed in order and have not yet been tried at the current state, backtrack by removing the last operator to be placed in sequence. Let the current state be the previous current state. If, however, the current state *prior to backtracking* is the initial state, stop (no feasible ordering can be found).
- (3) Select an operator which has not yet been placed in order and has not yet been tried at the current state (call this the *current operator*).
- (4) Evaluate any local constraints pertaining to the current operator at the current state. If a local constraint is violated, required preconditions for the operator have not been established, so go to step (2). Else, go to step (5).
- (5) Simulate the effect of applying the operator (using functional, local cause-and-effect, or dynamic models). Predict whether global constraints will be violated during or as a result of performing the task. If a global constraint is violated, go to step (2). Else, go to step (6).
- (6) Having simulated the effect of applying the current operator, and having determined its feasibility, place the operator next in the sequence, and update the current state to reflect application of the operator.
- (7) If all operators in the set have been placed in order, exit (with success). Else, go to step (2).

Questions for thought (refer to Figure 2):

1. List sources and sites of temperature and pressure for the reactor and for the flash drum. Repeat for liquid level in the flash drum.
2. Under what conditions is cooler #1 a source of liquid?
3. Under what conditions is the reactor a source of cyclohexane?

2.6 OVERALL ALGORITHM FOR SYNTHESIZING OPERATING PROCEDURES

The algorithm for procedure synthesis may be summarized by the following steps:

- (1) DECOMPOSE the system into subsystems [section 2.1].
- (2) Enumerate constraints

global to entire system and to subsystems:

- requirements for process chemistry
- avoidance of explosion & other hazards
- safety & environmental considerations
- avoidance of damage to equipment from corrosion, pressure, etc.

local to process units:

- required or forbidden conditions for performing unit manipulations

- (3) Identify overall operating strategy. This applies especially to planning startups. If the system contains subsystems with stationary states, decide how the stationary states will be used during the startup.
- (4) If necessary, propagate constraints from subsystems to upstream subsystems.
- (5) Identify operating goals (e.g., use means-ends analysis, discussed in Section 2.5).
- (6) Identify operators (unit manipulations, etc.) to satisfy goals.
- (7) Attempt to order operations to satisfy goals and constraints [Section 2.5].

Question for thought:

1. Using the strategy above, develop "high-level" procedures that are necessary to take the process in Figure 2 from a shut down, cold, air-filled condition to steady state operation. (Examples of high-level operations are "Purge by sweeping to *vent-header* with N_2 ," "Start compressor," etc.)

2.7 SECTION 2 SUMMARY

(Sec. 2.1) - The operation of chemical processing systems is viewed as a sequence of goal states. The set of actions which result in the goal state from an initial state is the synthesis of operating procedures. The state space model represents the procedure synthesis, with operators to move between states. The paths that the operations follow are many for any given system, with consideration given to the most feasible choices.

(Sec. 2.2) - Planning is facilitated by decomposition of the system into smaller subsystems. The following criteria apply:

- A subsystem is composed of a major process unit, with related instrumentation and connections.
- Subsystems should be physically isolated from neighboring subsystems.
- Subsystems should have stationary states.

A stationary state exists if:

- The subsystem is at a relatively steady state.
- Values of the state variables lie between shutdown and final run states.
- Connections with neighboring subsystems are closed to prevent interaction.

Processing units or subsystems with a large capacitance for physical quantity also have stationary states. Stationary states are useful for efficient procedure planning by providing convenient and verifiable stop-off points during operations. They also serve as focal points for overall operating strategies. Stationary states are used in planning as target states resembling "island-driven" planning in Artificial Intelligence, reducing the search space.

(Sec. 2.3) - Process units are represented by functional models, where units in a flowsheet are modelled as sources and sinks of energy, momentum, and material. Variables are defined globally within a subsystem, which take on multiple, discrete values.

(Sec. 2.4) - The following factors determine system constraints:

- Preconditions for unit operations.

- Requirements for a reaction.
- Production requirements.
- Hazards.
- Materials of construction.

Constraints are used to limit the search space and reduce the planning effort. Local and global constraints exist, depending on the location and the way they are used in the planning problem.

(Sec. 2.5) - The decision-making method involves:

- Identifying conditions which the operating procedures must change.
- Translating the identified changes into tasks.
- Ensuring the sequence of tasks achieve the plant operation goals.

Planning may be posed as a means-ends analysis problem with the initial and goal states characterized by vectors describing the process at both ends. The initial and final states are compared and differences are discovered. Next, operators are searched for to satisfy each goal. This search produces a set of unit manipulations. Planning will then proceed hierarchically from macroscopic tasks down to subtasks. This depth-first, forward search is used to discover sequences of operators which meet operating goals without violating system constraints.

3. EXAMPLE OF PROCEDURE SYNTHESIS

3.1 SYSTEM DESCRIPTION

To demonstrate our methods of operating procedure synthesis, consider the problem of startup of a chloroform plant. Figure 4 shows the reaction subsystem of this plant, in which chloroform is produced [1] according to the reaction

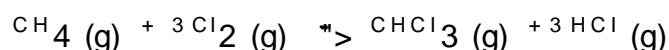

The reactor is a large plug-flow reactor and the reaction is uncatalyzed and occurs at high temperature and pressure. Methane and chlorine enter the reactor loop through flow mixers. The reactor effluent is passed through a condenser which performs a rough separation of the material into streams containing chloroform (and carbon tetrachloride by-product) and underchlorinated. The underchlorinated stream is recycled through a compressor and mixed with the feed streams. HCl, a by-product of the reaction, is used as a diluent. To control the concentration of HCl in the system, part of the recycle stream is sent to a separation system which removes HCl.

In addition to the major feed and process units, there are vent headers for hydrocarbons and for chlorine. The system can also be vented to the atmosphere. A dry nitrogen feed source is available for purging.

Although we will consider only the reaction subsystem, there are other subsystems in the overall processing plant. Upstream from the reactor subsystem are feed storage and preparation subsystems. Downstream are the HCl separation system, the chloroform product refinement train, and a product storage facility. As a recycle reactor loop, the reaction subsystem has a stationary state. The system is inventoried with the diluent and one of the reactants, which are cycled at high pressure and temperature. In this way, this subsystem is prepared for the reaction, and can be brought to steady-state run conditions when the other subsystems of the plant are also ready.

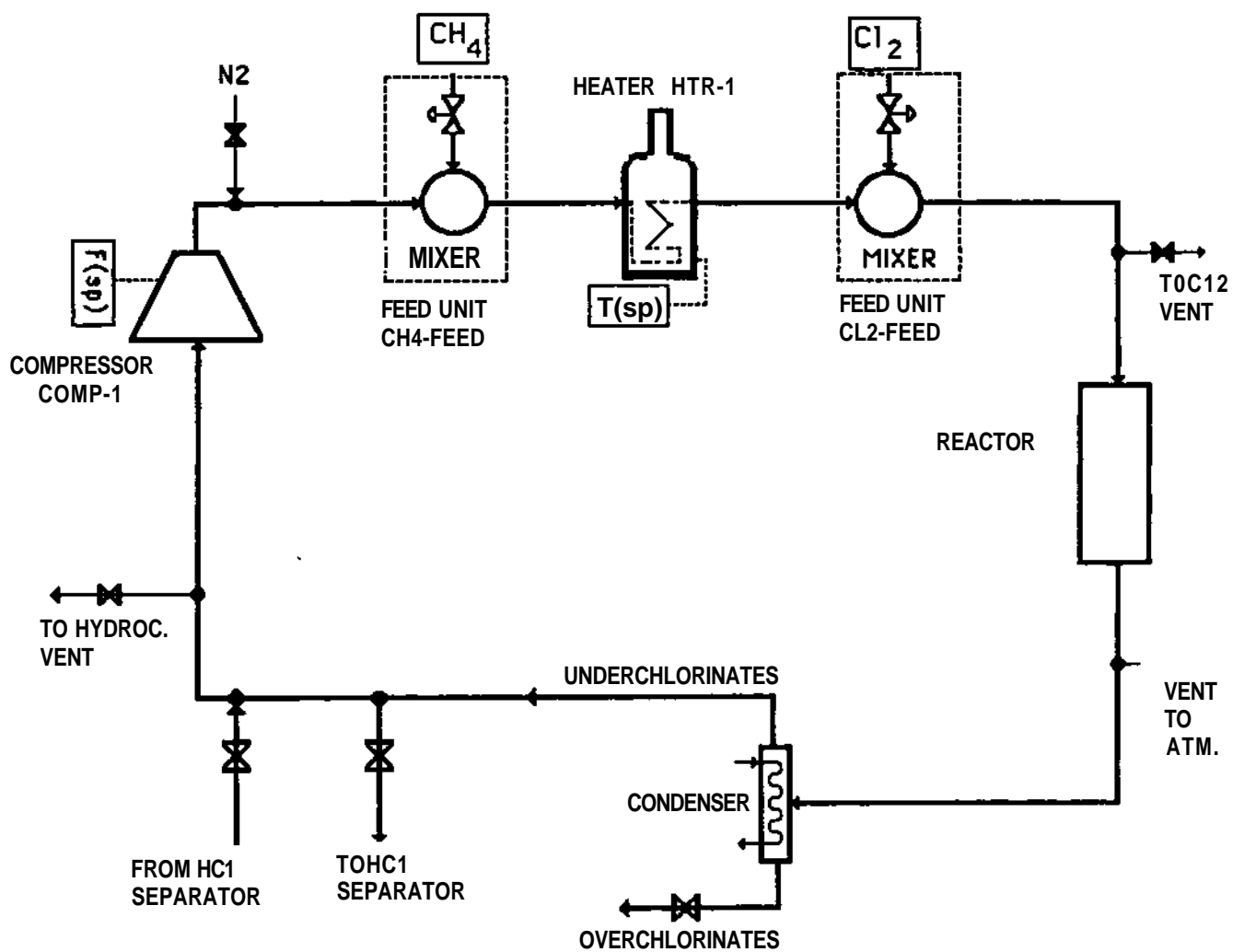

Figure 4. Simplified chlorination flowsheet

[Key: sp = set point, F = flow rate, T = temperature]

3.2 CONSTRAINTS

The constraints which are used to guide startup planning are listed in Tables 1 and 2. For the remainder of this example, constraints will be referred to by the labels given in those tables.

Global constraints gl-constr-1 and gl-constr-2 are motivated by avoidance of explosive mixtures of CH_4 and Cl_2 in certain locations in the plant. For this reason, it is required that Cl_2 be consumed in a single pass through the reactor. Constraint gl-constr-2 ensures that underchlorinates (CH_4 , CH_3Cl , CH_2Cl_2) are kept in excess, and gl-constr-1 ensures that Cl_2 will not be introduced unless reaction can occur. Constraint gl-constr-3 is an example of a constraint being propagated upstream from another subsystem. This constraint is used to avoid sending inert gases like N_2 into the HCl separation system.

Local constraints lcl-constr-1 through lcl-constr-4 in Table 2 are statements of preconditions for operating the mixer, compressor, and heater units. Constraints lcl-constr-5 through lcl-constr-8 are (with respect to the reactor subsystem) local constraints on valve operations. It should be noted that lcl-constr-5 expresses a "hard" constraint that no hydrocarbons enter the chlorine vent header, where an explosion could occur. There is an accompanying "soft" constraint that *only* chlorine should be allowed to enter the chlorine vent header. Soft constraints express preferred conditions, but can be relaxed if necessary.

3.3 STARTUP STRATEGY

The startup strategy for this system will take advantage of stationary states in the reaction loop and neighboring subsystems. The subsystems will be brought to "standby" conditions (e.g., the reactor loop will be brought to total recycle, a downstream distillation train will be brought to total reflux), then the subsystems will be integrated and brought to steady-state run conditions. Figure 5 shows the comparison of the initial (shutdown) and intermediate (stationary) states. The state vectors are defined at the

Table 1. Global constraints used in example startup problem.

gl-constr-1:

Do not mix chlorine and methane unless the system temperature is high (above reaction initiation temperature).

gl-constr-2:

Do not allow chlorine to exceed a stoichiometric amount (for trichlorinaton) relative to methane.

[These global constraints are meant to avoid potentially dangerous mixtures of methane and chlorine.]

gl-constr-3:

No unnecessary noncondensable gases should be present in the reaction subsystem when it is open to the HCl separator.

[Propagated upstream from the HCl separation subsystem, where noncondensable gases will affect condenser performance.]

gl-constr-4:

Do not mix HCl and H₂O.

[To avoid corrosive conditions]

gl-constr-5:

Do not mix O₂ and hydrocarbons.

[To avoid an explosive mixture]

Table 2. Local constraints used in example startup problem.

lcl-constr-1:

Do not start unit Cl₂-feed with no bulk flow in system.

lcl-constr-2:

Do not start unit CH₄-feed with no bulk flow in system.

[The above constraints are meant to avoid locally explosive mixtures.

Adequate mixing at each of the feed points depends on bulk flow in the line.]

lcl-constr-3:

Do not start compressor comp-1 with density = high.

[to avoid surge condition]

lcl-constr-4:

Do not start heater htr-1 with no bulk flow in system.

[to avoid burning the tubes]

lcl-constr-5:

No hydrocarbons should enter the Cl₂ vent header.

lcl-constr-6:

No O₂ should enter the hydrocarbons vent header.

lcl-constr-7:

No Cl₂ should enter the hydrocarbons vent header.

[The above 3 constraints are meant to avoid explosive mixtures in vent headers.]

lcl-constr-8:

HCl, methane, chlorine, etc. should NOT be vented to the atmosphere.

[from environmental and safety considerations]

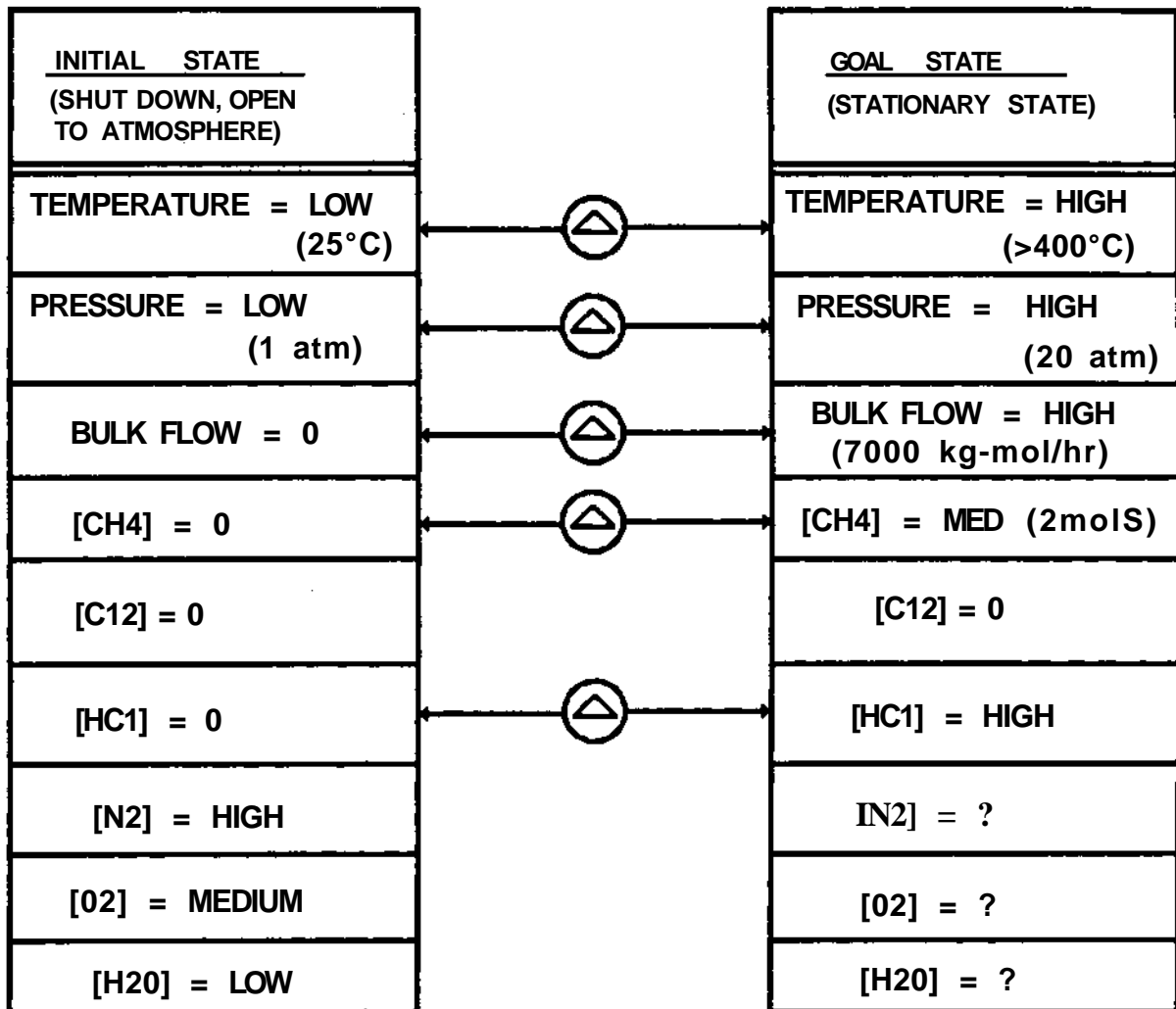

Figure 5. Comparison of state vectors between shut down and stationary states.

reactor entrance. From the differences shown in Figure 5, the following operating goals are formulated:

INCREASE TEMPERATURE from LOW to HIGH

INCREASE PRESSURE from LOW to HIGH

INCREASE BULK FLOW from 0 to HIGH

INCREASE [CH₂] from 0 to MEDIUM

INCREASE [HCl] from 0 to HIGH

Note that, in Figure 5, the concentrations of the atmospheric species (N₂, O₂, H₂O) at the goal state are not known *a priori*. It is known that they are not *required* species, but we need to examine the constraints in order to know if they are *forbidden*. By checking the list of global constraints, we see that gl-constr-4 and gl-constr-5 forbid the presence of O₂ and H₂O at the stationary state. Constraint gl-constr-3 will cause N₂ to be forbidden when the connection between the reaction subsystem and the HCl separator is open.

Thus we have the following purge goals:

DECREASE [O₂] from MEDIUM to 0

DECREASE [N₂] from HIGH to 0

DECREASE [H₂O] from LOW to 0.

We will seek to satisfy the purge goals first, just as a chemist will purge an apparatus before performing an experiment.

When planning purge operations, we must be aware that the various species may be present in different phases and subject to different constraints, so they are handled separately. For each component to be purged, there must be chosen a *method* for purging, a *purgative* or fluid which is used to push out the undesirable material, and the *destination* to which the material will be removed. The purge operations must also be ordered to satisfy constraints. The systematic planning of purge operations is a large combinatorial problem, and cannot be fully covered here.

A source of dry nitrogen is available for use as a purgative, and any of the system species (those required in the system at the goal state) are candidate purgatives. A

commonly used purge method for gases is to pressure up the system with a gas and blow down through the vents. For absorbed liquids such as water, a common method is to sweep the system out with a hot gas. The candidate destinations are the vents and vent headers.

The first purgative gas that will be considered is HCl. Because HCl will be present in large concentration at the goal state, it is a desirable purgative. ("Try to kill multiple birds with a single stone" is a useful heuristic to use in operating procedure planning.) Examining the global constraints, it is found that gl-constr-4 forbids the use of HCl to purge H₂O. Examination of local constraints reveals that HCl should only be vented to the vent header, while O₂ should only be vented to the atmosphere. This incompatibility of destinations leads to the conclusion that HCl cannot be used as a purgative for O₂. Thus, it is decided to use N₂ to purge O₂ and H₂O and to use HCl to purge N₂. The following ordering of purge operations will satisfy the purge goals and the constraints:

1. Purge O₂ by pressure up/blow down with purgative N₂ to the atmosphere.
2. Purge H₂O by sweeping with hot N₂ to the atmosphere.
3. Purge N₂ by pressure up/blow down with HCl to the hydrocarbons vent header.

3.4 PLANNING BETWEEN PURGE AND STATIONARY STATE

The purge operations will alter the state variables, so it is necessary to recompare the state vectors and check the operating goals. Figure 6 shows the recomparison of states, which are defined at the reactor entrance. The previous [HCl] goal has been satisfied. The other operating goals are the same as those found previously (increase temperature, pressure, bulk flow, and methane concentration), except for different starting values of temperature and pressure. The concept of source/sink manipulations is used to find appropriate operations to satisfy the goals. As discussed in Section 2.5, given the operating goal:

INCREASE TEMPERATURE from MEDIUM (200-250°C) to HIGH (> 300°C)

we seek to increase the operating level of a source of thermal energy or to decrease the

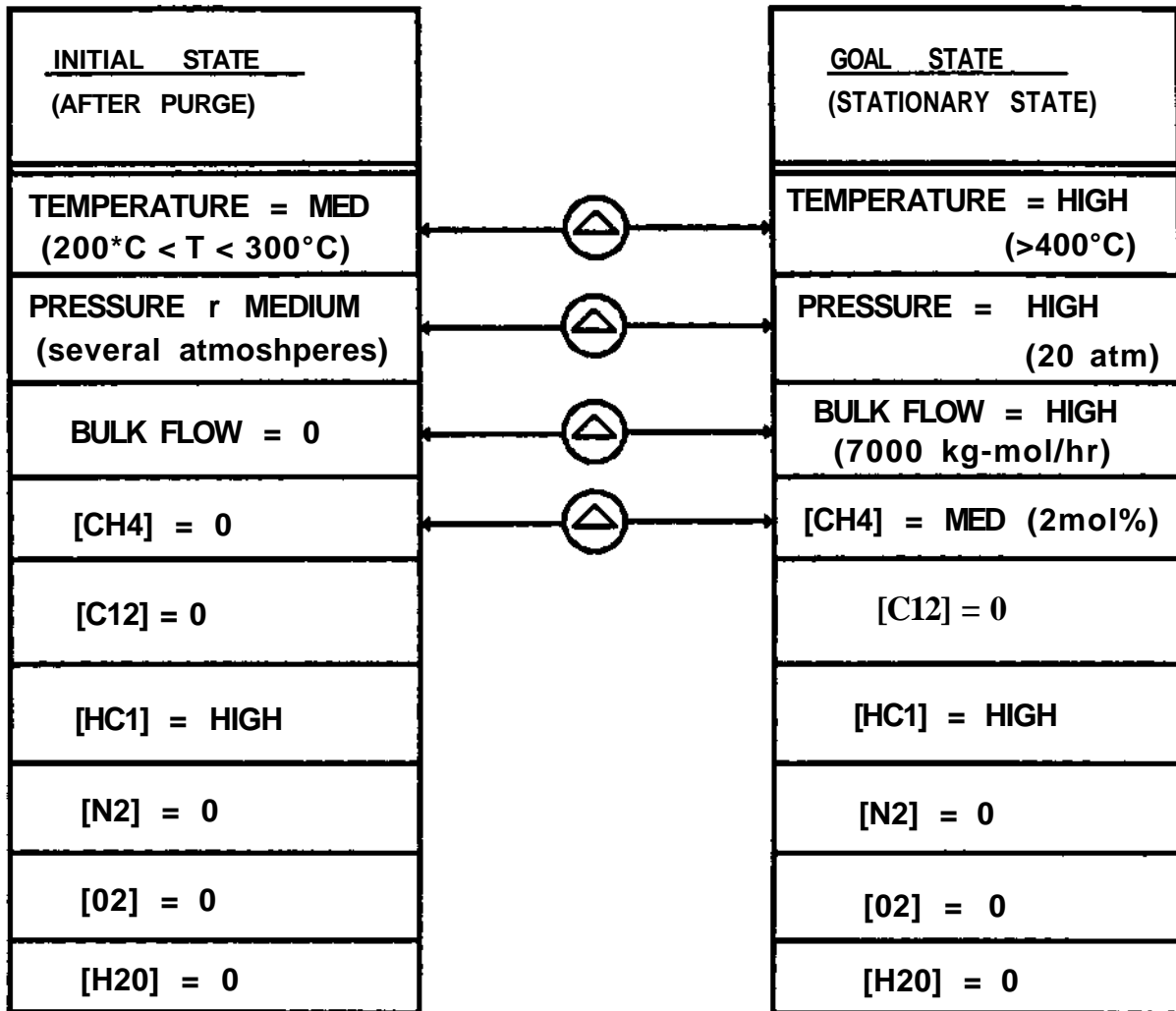

Figure 6. Comparison of state vectors after purge.

operating level of a sink of thermal energy. In the chlorination reactor system, the only possible operation is to use the heater to raise the system temperature. Following similar reasoning, the following unit manipulations are proposed (in no particular order):

START HEATER HTR-1 to level HIGH (temperature set point)

START FEED UNIT CH4-FEED until [CH⁴] = MEDIUM

START COMPRESSOR COMP-1 to level HIGH (flow set point).

Figure 7 shows a reasoning path for ordering the operators according to the algorithm of Section 2.5. The "initial" state in this case is the one defined by the left vector in Figure 6. If an attempt is made to place the operator "START HEATER HTR-1" first in order, it is found that local constraint lcl-constr-4 is violated. Thus, the left planning path in Figure 7 is closed. No local constraint violations are found by applying the operator "START COMPRESSOR COMP-1," and so the effects of this operator are simulated (the bulk flow in the subsystem is increased to HIGH and the temperature and pressure are raised slightly). The next step in determining the feasibility of this operator application is to test for global constraint violations under the new conditions. As no global constraint violations are found, the operator "START COMPRESSOR" is placed first in order, and the current state is updated. The operator "START HEATER HTR-1" is retried at the new current state, and no local constraint violations are found. Simulating the effect of this operator (the temperature is raised to HIGH and the pressure is raised), none of the global constraints is violated. The "START HEATER" operator is then placed second in the sequence. The remaining operator, "START CH4-FEED until [CH₄] = MEDIUM," is similarly shown to be feasible when placed third in the sequence. Thus, the desired stationary state is reached by the sequence:

1. **START COMPRESSOR COMP-1 to level HIGH (flow set point)**
2. **START HEATER HTR-1 to level HIGH (temperature set point)**
3. **START FEED UNIT CH4-FEED until [CH₄] = MEDIUM.**

This path is shown on the right in Figure 7.

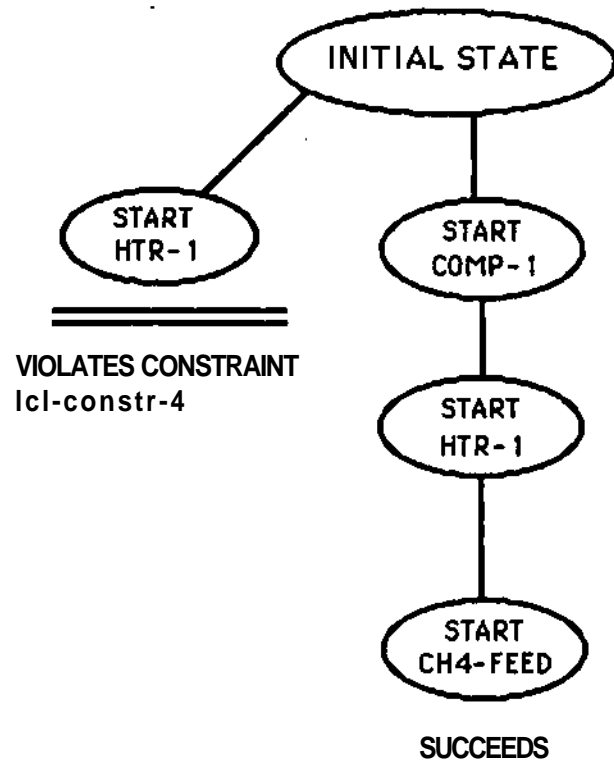

Figure 7 . Planning path for example startup problem.

3.5 PLANNING BETWEEN STANDBY AND RUN STATES

The process of finding a sequence of operations for bringing the chloroform plant from standby to steady-state run conditions is similar to that described in the previous section. For the reaction subsystem, the initial state at this stage of planning is the stationary state, and the final state is given by the design specifications. As in previous stages of planning, all operating steps are subject to local and global (to the subsystems and to the entire plant) constraints. Keep in mind that, as adjacent subsystems exchange process material, the effluent stream of an upstream subsystem becomes subject to the constraints of the downstream subsystem. This is how constraints "propagate." An example of this is constraint gl-constr-3 in Table 1 (No noncondensable gases into HCl separator). It is also important to account for the propagation of disturbances between subsystems. At standby conditions, a reaction subsystem may be at higher pressure than a downstream distillation subsystem. If the connection between the two subsystems is opened too quickly, damage to equipment may result because of pressure hammer. A too-rapid opening of the connection could also result in flooding a distillation column, resulting in a delay while re-establishing equilibrium in the column. Dynamic simulations or experimental investigations may be necessary to determine acceptable practices.

Questions for thought:

1. For the chloroform reaction system in figure 4, if the additional constraint of "the reactor effluent temperature must be less than 450 degrees centigrade (to prevent thermal stress)" is considered, how does the startup sequence given in this example have to be changed?
2. Are the following sequences of procedures for starting up the chlorination system feasible with respect to the constraints given in Tables 1 and 2? If not, why?

PROCEDURE 1

1. START COMPRESSOR COMP-1 to level HIGH (flow set point).
2. START HEATER HTR-1 to level HIGH (temperature set point).
3. START FEED UNIT Cl₂-FEED until [Cl₂] = MEDIUM.
4. START FEED UNIT CH₄-FEED until [CH₄] = MEDIUM.

PROCEDURE 2

1. PURGE O₂ by sweeping with purgative N₂ to the atmosphere.
2. PURGE H₂O by sweeping with hot N₂ to the atmosphere.
3. START COMPRESSOR COMP-1 to level HIGH (flow set point).
4. START HEATER HTR-1 to level HIGH (temperature set point).
5. START FEED UNIT CH₄-FEED until [CH₄] = MEDIUM.
6. PURGE N₂ by pressure up/blow down with HCl to the hydrocarbon vent header.

3. If the reactor in Figure 4 were changed to a large CSTR in which the liquid phase is chloroform, how would the flowsheet change? How do the startup procedures differ from the flowsheet with the vapor phase tubular reactor?
Consider:

- a. New global and local constraints.
- b. Different stationary states.
- c. Different models for the reactor, etc.

REFERENCES

1. G.T. Austin, *Shreve's Chemical Process Industries (5th Ed.)*, McGraw-Hill, New York (1984), p. 759.
2. P.P. Chakrabarti, S. Ghose, and S.C. DeSarkar, Heuristic Search Through Islands. *Artificial Intelligence* 29, 339-347(1986).
3. R.E. Fikes and N.J. Nilsson, STRIPS: A New Approach to the Application of Theorem Proving to Problem Solving. *Artificial Intelligence* 2, 189-208(1971).
4. R.H. Fusillo and G.J. Powers, A Systematic Method for Chemical Plant Operating Procedures. *Computers in Chemical Engineering*, To Appear (1987).
5. R.H. Fusillo and G.J. Powers, Computer-Aided Planning of Purge Operations. Submitted to *AICHE Journal*, May, 1987.
6. R. Govind, Ph.D. Thesis, Carnegie-Mellon University, Department of Chemical Engineering (1978).
7. V.A. Ivanov, V.V.Kafarov, V.L. Kafarov, and A.A. Reznichenko, On Algorithmization of the Startup of Chemical Productions. *Engineering Cybernetics* 18, 104-110 (1980).
8. V.A. Ivanov, V.V.Kafarov, V.L. Kafarov, and A.A. Reznichenko, Design Principles for Chemical Production Startup Algorithms. *Automation and Remote Control*, 41, 1023-1032 (1980).
9. A. Kinoshita, T. Umeda, and E. O'Shima, An Algorithm for Synthesis of Operational Sequences of Chemical Processing Plants. In *Computerized Control and Operation of Chemical Plants, Vienna, Austria, September, 1981*. Osterreichischer Chemiker, Wien Austria (1981).
10. S.A. Lapp and G.J. Powers, Computer-Aided Synthesis of Fault Trees. *IEEE Trans. Reliability* R-26, 2-13(1977).
11. E. O'Shima, Safety Supervision of Valve Operations. *Journal of Chemical Engineering of Japan*, 11, 390-395(1978).
12. J.R. Rivas and D.F. Rudd, Synthesis of Failure-Safe Operations. *AICHE Journal*, 20, 320-325 (1974).
13. D.F. Rudd, G.J. Powers, and J.J. Siirola, *Process Synthesis*. Prentice Hall, Englewood Cliffs, N.J. (1973).
14. J.J. Siirola and D.F. Rudd, Computer-Aided Synthesis of Chemical Process Designs. *Ind. Eng. Chem. Fund.* 10, 353-362(1971).
15. *Process Input Manual*, Simulation Sciences, Inc., Fullerton, Ca. (1983), p. 81.2.
16. M.J. Stefik, Planning With Constraints (MOLGEN, Part 1). *Artificial Intelligence* 16, 111-139(1981).